

Installation Guide

Version 03-20D

SD Sliding Gate Opener

Features	1
Technical Specifications	
Installation	2
Manual Release	4
Confirm Direction of Travel	
Wiring	5
Wiring for Optional Accessories	6
Remote Control Setting	7
Gate Opener Setup	8
Solar Panel Installation	12
Self Debug and Error Code List	14



1. Features:

1. Fully built-in compact design with fashionable streamline
2. Pedestrian opening or full open function
3. Auto closing delay time adjustable
4. Facility for optional Backup Battery
5. Adjustable slow down distance at start and at end of the travel
6. Digital gate limits positioning system (DLPS)
7. Electronic soft start and soft stop
8. Magnetic limit switch control (optional)
9. Facility for optional Photocell Sensor to stop the gate if see an obstacle
10. Automatic stop when meet an obstacle during opening cycle
11. Auto stop and reverse when meet an obstacle during closing cycle
12. Facility for optional solar power system
13. Backup Battery or Solar System Battery status display

2. Technical Specifications

■ Electrical

Power supply	AC110V or 240V ± 10%, 50 HZ
Operating Voltage	DC 24V
Electronic Controller	Microcontroller Based
Safety Detection	Over Current Detection
Safety Barrier	Infrared Beam Sensor (optional)
IP Rating	IP57



■ Mechanical

Model	SD
Max. Gate Weight	800 kg
Motor speed	1800 rpm
Gate moving speed	13m/min
Gate Limit type	Intelligent Position Detection/ Magnetic Limit Switch (optional)
Operating distance	≤50m Frequency: 433.92MHz
Remote control mode	Close/ Open/ Stop/ Pedestrian Opening
Auto close time	0~99 sec (Adjustable)
Noise	≤65dB
Product actual size	29*22*23cm
Packing size	36*29*36cm
Environmental temperature	-15°C to +55°C



SD

Sliding Gate Opener

3. Installation

Motor Dimension

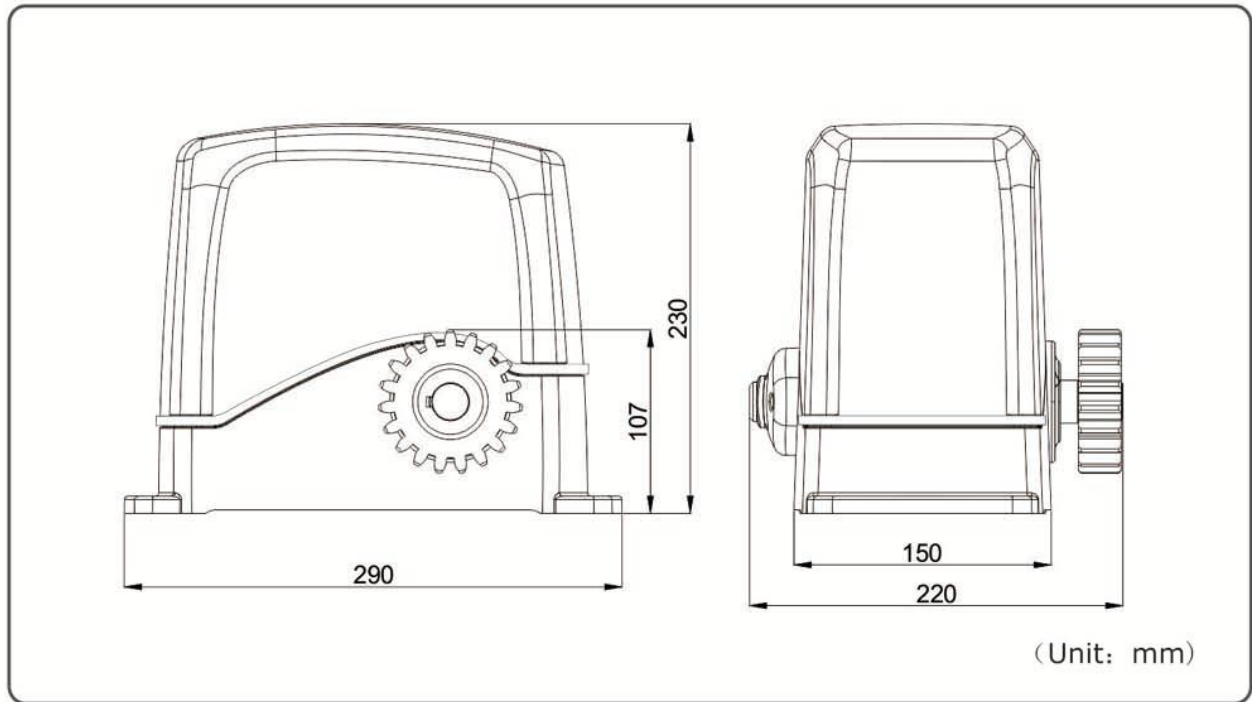

Gear & Rack Installation

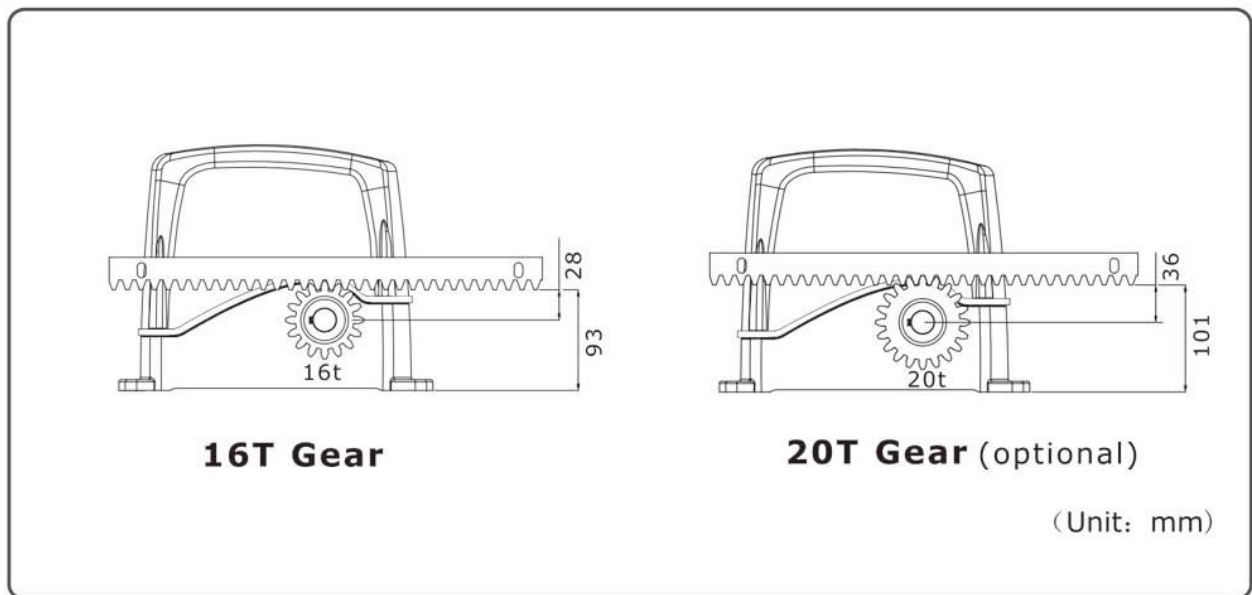

Installation Diagram

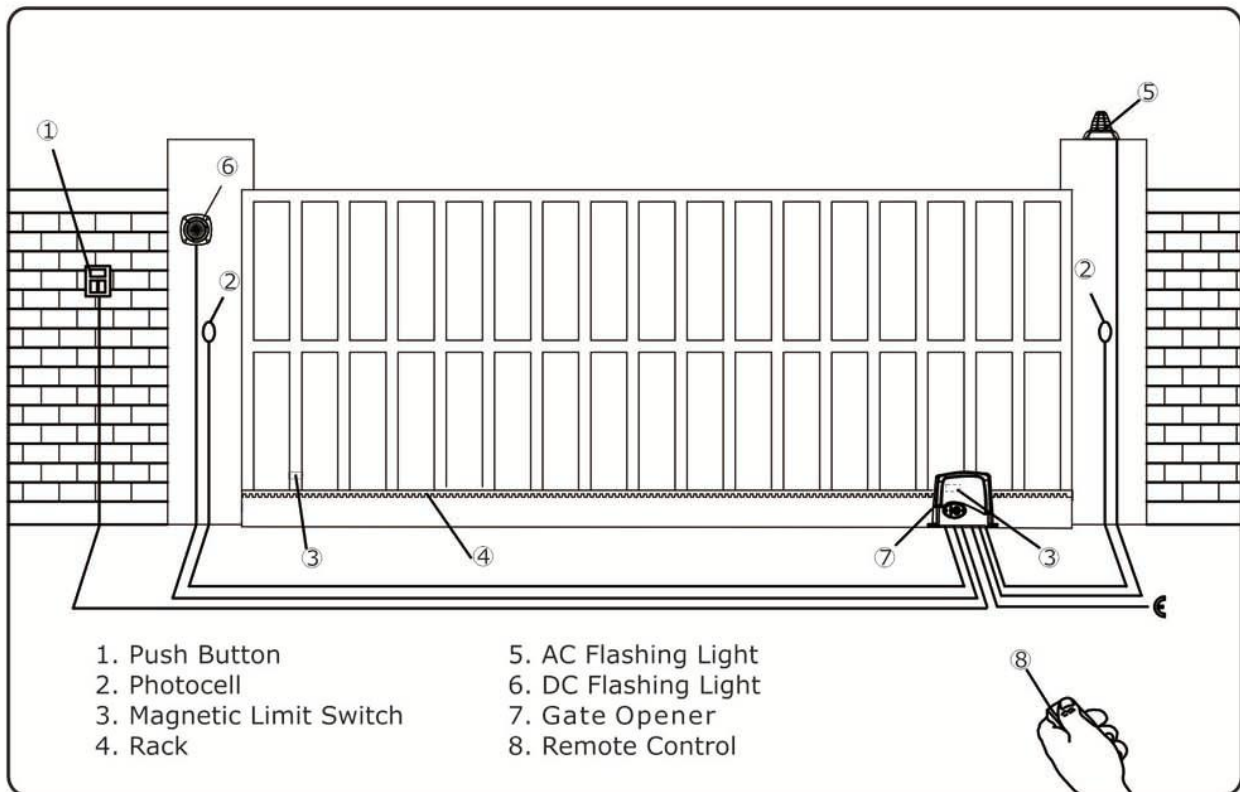

Motor & Rack Installation

1. Fix the motor on the ground
(Please make sure the motor is installed at a high position to avoid flooding)
2. Manual release the gate opener (Following steps on page 4).
3. Fix the rack onto the gate, keep 1-2mm clearance between the rack and gear.
4. Move the gate several times with hand, make sure the rack work well with the gear, and the gate can move smoothly.
5. Undo manual release to work on electrics.

*After finishing wiring and gate opener setup, Please tighten the screws of cover and seal the wire entry hole to avoid water.

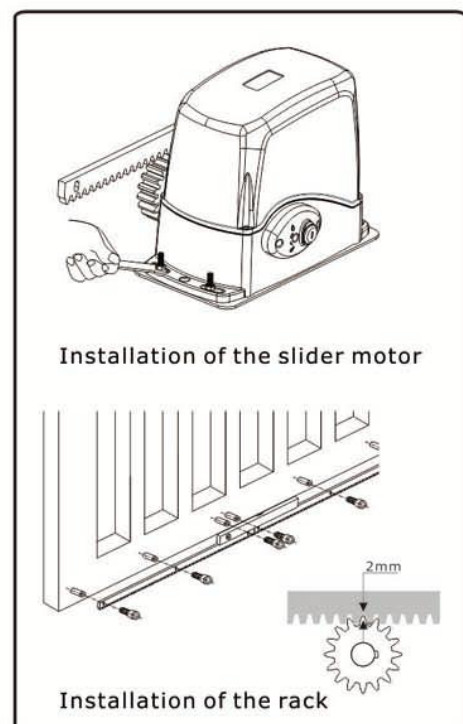

4. Manual Release

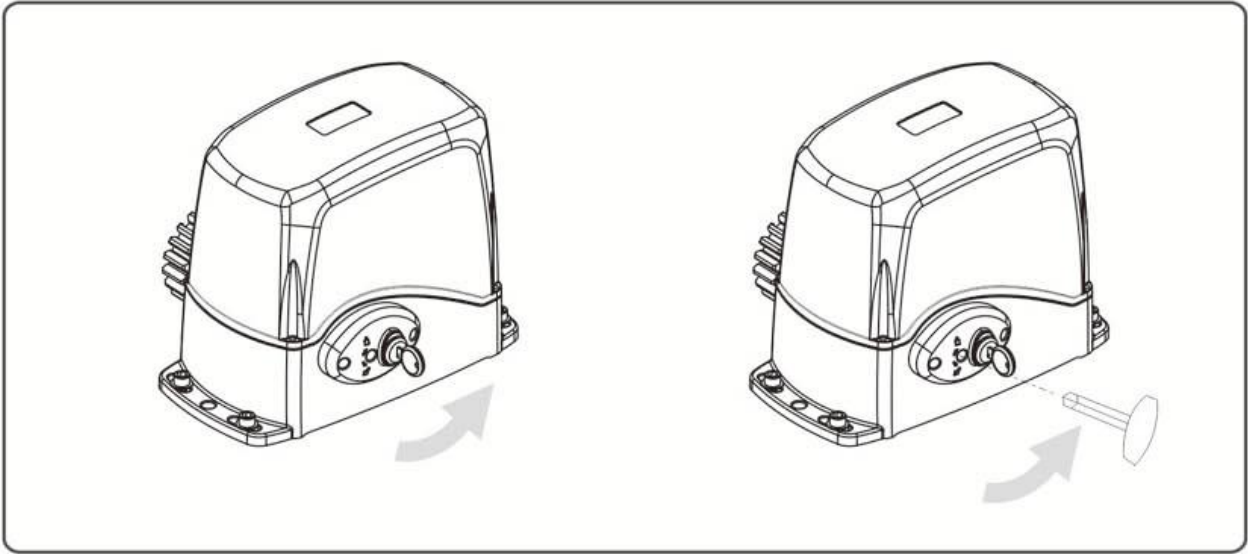

Place the key in key slot and turn it to 12 o'clock, this will allow the allen key supplied to fit into the hole, rotate allen key 90 degree counterclockwise, The gear can now be rotated manually. Reverse steps to lock the drive gear.

* Read all instructions fully before proceeding with initial set up.

5. Before Installation Confirm Direction of Travel

Lift up the gate to disengage gear rack from the drive gear wheel, press the open button on the remote and check if the gear drive is turning in the direction your gate is required to open.

To change motor direction:

Older models (before 2013) reverse the "red +" and "black -" terminals on the motors Pc board.

Newer models (after 2013) ref to adjustment setting B3 (page 10).

Make sure power is switched off before doing this step.



6. Wiring

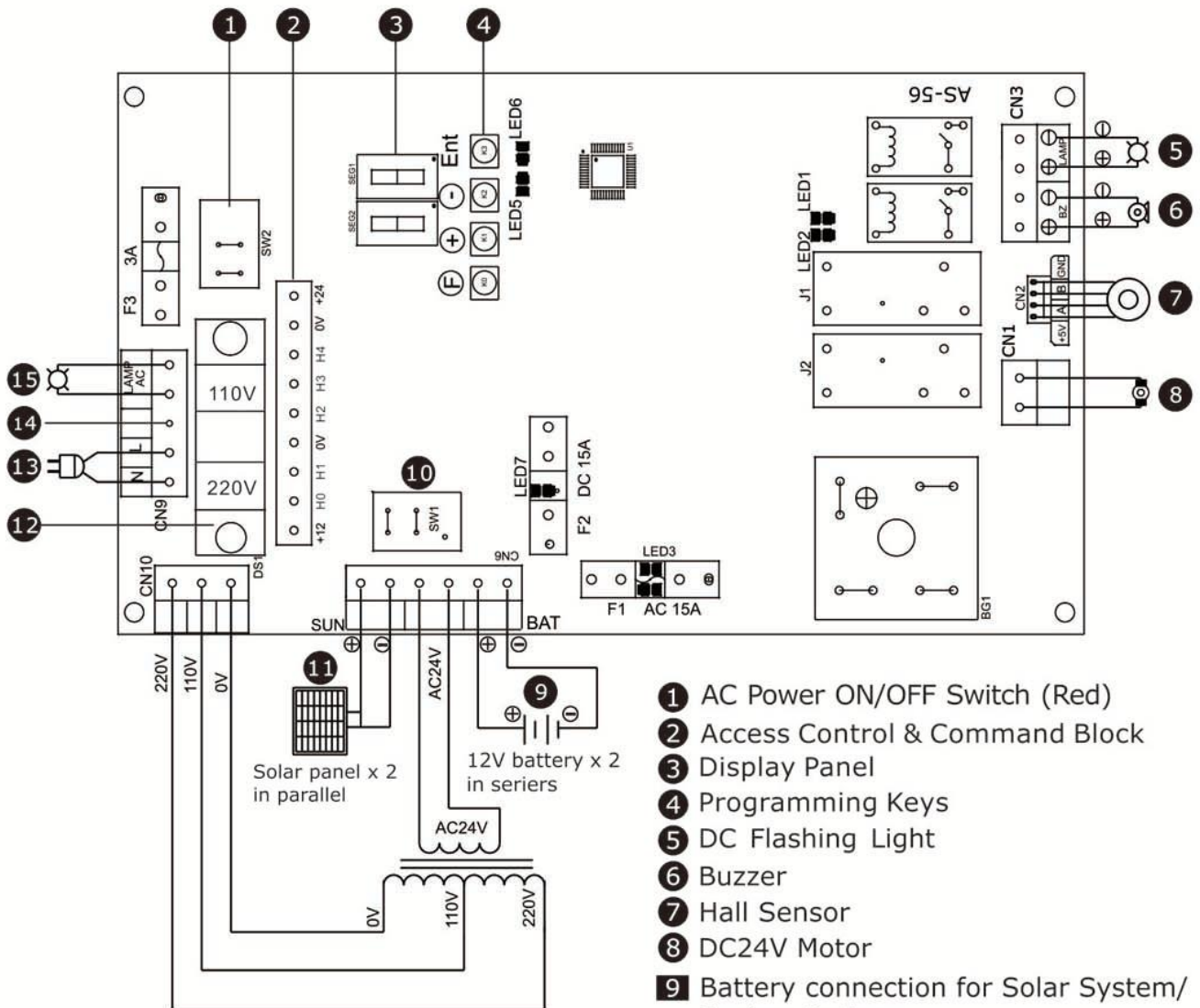

LED Diagram

Power on, Red LED5 will blink.

LED1 Open LED

LED2 Close LED

LED5 Power LED

LED6 Received signal for remote control LED

- 1 AC Power ON/OFF Switch (Red)
- 2 Access Control & Command Block
- 3 Display Panel
- 4 Programming Keys
- 5 DC Flashing Light
- 6 Buzzer
- 7 Hall Sensor
- 8 DC24V Motor
- 9 Battery connection for Solar System/ Backup Battery
(2 x 12V batteries in series. Check polarity)
- 10 Power ON/OFF Switch (Black)
(AC power and battery)
- 11 Solar Panel Input
(2 x solar panels in parallel. Check polarity)
- 12 Selector Switch for AC 220v or 110V
(not used in 24V supply system)
- 13 Power Supply (not used in 24V supply system)
- 14 Earth wire connection
(not used in 24V supply system)
- 15 AC Flashing Light (not used in 24V system)

* Make sure the "12 selector switch for AC 220v or 110V" is at the correct position before power on

* Please switch off the power before connecting any accessories



Wiring for Optional Accessories

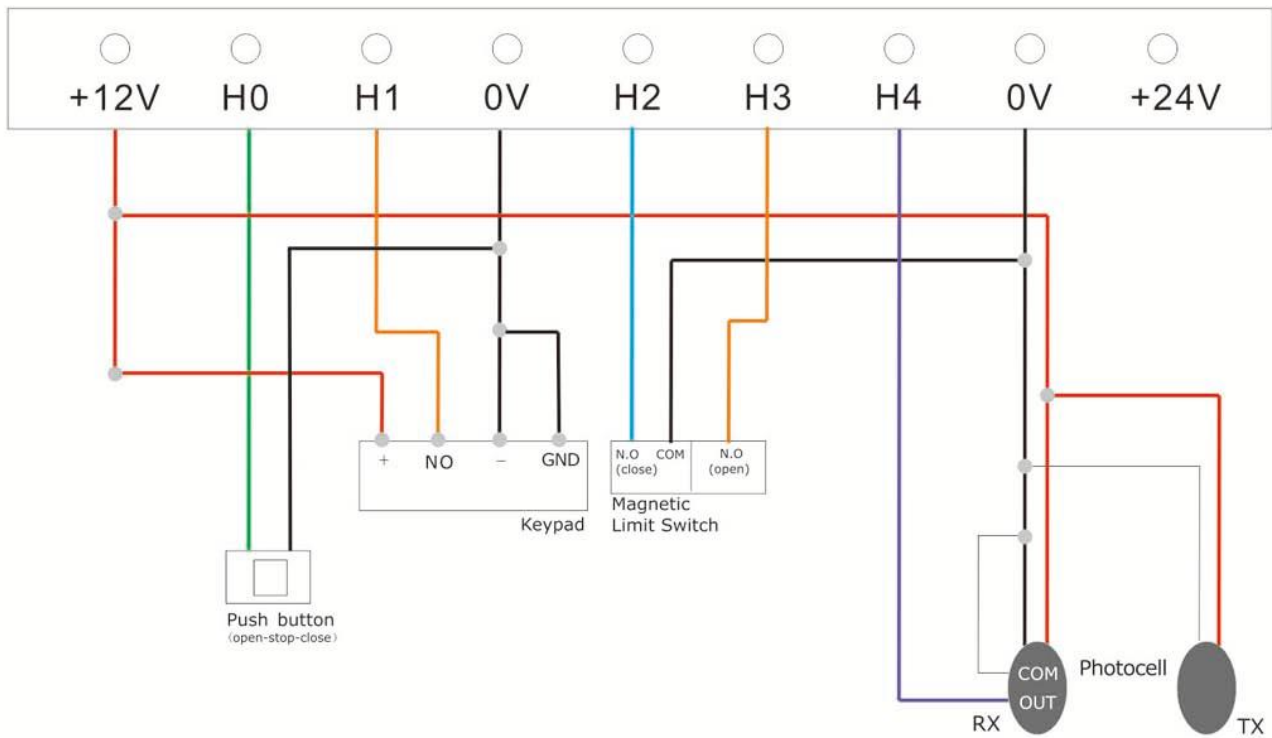

Item	+12V	H0	H1	0V	H2	H3	H4	0V	+24V
Description	Stable voltage output	Open/ Stop/ Close	Only Open	"-" & "Concentration line"	close limit	open limit	Sensor	"-" & "Concentration line"	Unstable voltage output
Keypad	●		●	● ●					
Push button		●		●					
Photocell (sender)	●							●	
Photocell (receiver)	●						●	● ●	
Magnetic Limit Switch					●	●		●	

● "Means the connection port

* Please switch off the power before connecting any accessories

* Instructions for photocell:

During gate is in closing cycle, if Photocell sees an obstruction, gate will stop immediately and travel to open position. In order to close the gate.

1. Obstruction has to clear
2. Activate the gate to close again



7. Remote Control Setting

Activating the Remote Control

Press and hold the "F" button for approximately 2 seconds until the indicator displays "FF" and keeps flashing , then release the "F" button.

Press "□stop" button on the remote control, if the display stops flashing "FF", it means the remote control is programmed to the PCB and is valid.

- * 50 remote controls can be set at most
- * Verify the remote control is operating by pressing a button on the remote, when press any button on the remote control, the LED6 (on the PCB) will be on.

Erasing the Code

Press and hold the "F" button for approximately 2 seconds until the indicator displays "FF" and keeps flashing , then release the "F" button.

Press and hold the "Enter" button until the display stops flashing "FF", this indicates all remotes have been erased and are invalid.

- * Pedestrian opening push "Ⓟ" button to perform half open

- * When remote control signal weakens , please replace the battery of remote control and check the receiver on the control board
Weak signal will shorten the distance of remote control or send wrong instruction to control board
- * If the remote control can't be set , please Erasing all the code and then activate the remote control you want to use 

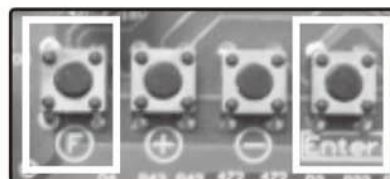

433MHZ Remote control



8. Gate Opener Setup (Software Setup)

1. If without limit switch, Gate should have hard stop at the close ends
2. If you are using magnetic limits, make sure to set up magnets in such a way that gate stops few millimetres before it hits the hard stop (both open and close ends)
3. Open the gate fully and make sure mechanical manual release is off (gate can't be moved manually)
4. Remove the top cover of the gate opener to access control board, Press and hold on "+" button for couple of seconds to go into programming mode, you will see "AA" blinking on the display panel, now you are in programming mode.
5. While you are in programming mode, press "**CLOSE**" button on the remote control, gate will travel slow speed to closed position and hit the stopper and stop the gate. (If you have fitted limit switch, gate will stop when the gate opener sees the close magnet). then gate will automatically travel to open position at slow speed.
6. Gate will hit the stopper at open position and stop the gate, if without stopper, please press "**STOP**" button on the remote control to stop the gate. (If you have fitted limit switch, gate will stop when the gate opener sees the open magnet)
7. Gate opener will automatically exit programming mode, Now the gate is ready for normal operation. However don't disturb the gate when you are doing the above procedure

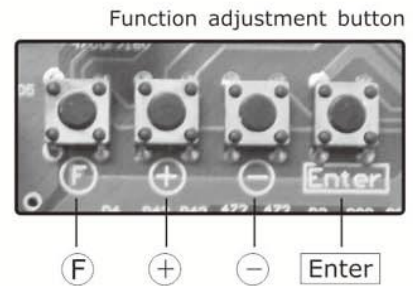

Remote Control

Reset Gate Limits memory after power failure.

Simply press and release "**CLOSE**" button on the remote control. Gate will travel to close position and stop. System will initialize the normal operation. Now you are ready for normal operation of the gate.

When power reset, only "**close**" and "**stop**" button is valid, "**open**" button is invalid, After gate travel to close position and stop, then the "**open**" button is valid.

If met obstacles and stopped, it will require to turn off power and start the procedure above again.

Reset the Gate Opener to Factory Settings.

If you have already installed the gate opener and you need to do a set up again, it is a good idea to reset all the parameters to factory settings before the set up. Simply, manually set parameter D2 to "9" (refer to "How to Adjust the Parameters" below). This will set all the parameters to factory setting in one go.



Program Parameters and Manual Adjustment

This gate opener has many parameters. Value of each parameter is unique for each and every installation. When you carry out Gate Opener Setup, parameters will be automatically set to optimum values. However, due to variations of atmospheric conditions (wind etc) and gate's mechanical properties (dry bearings in travelling wheels etc) sometimes parameters may need manual adjustments.

Following chart shows the parameters, what those parameters stands for and factory setting values of each and every parameter.

How to Adjust/ View Parameters and Values

1. Remove the Gate Opener top cover.
2. On the control board there are 4 Function Adjustment Buttons (Programming Keys).
3. If there is nothing showing on the Display Panel, briefly press and release "F" button.
4. Keep pressing "+" or "-" buttons until Display Panel to shows "A1".
5. When you at "A1" press "F" button once. Display will now show the value of "A1" parameter.
6. At this point you can use "+" or "-" buttons again to change the value (of "A1" parameter).
7. Once you have changed it to the preferred value, press "ENTER" button to confirm the value.
8. Display Panel will show "A1". Now you have successfully changed the value of "A1" parameter.
9. Press "+" button once and Display Panel will now show "A2".
10. Press "F" button once. Display will show the value of "A2" parameter.
11. Keep doing above steps 6 to 8 to change value of "A2" parameter.
12. Likewise, you can check or change the values of all the parameters.



Parameters

Items	Descriptions	Setting Range	Default setting	Remarks
A1	Sensitivity to stop the gate due to resistance	0-99	60	Lower setting means door will be more sensitive to stop
A2	Fine adjust the opening travel	0-99	30	If gate hits the end stopper, increase this item If door can't reach the end ,reduce this item
A3	Fine adjust the closing travel	0-99	30	If gate hits the end stopper, increase this item If door can't reach the end ,reduce this item
A6	Motor Speed when traveling at slow speed (the end of the travel)	0-99	50	
A7	Motor Speed when traveling at fast speed (the forepart of the travel)	0-99	99	
A8	Distance of gate travel at slow speed towards the end of the travel during opening cycle	0-99	35	
A9	Distance of gate travel at slow speed towards the end of the travel during closing cycle	0-99	35	
B0	Time from fast to slow speed	0-99	50	The larger the number, the shorter the time from fast to slow speed
B1	Time from slow to fast speed when motor starts	0-99	50	The larger the number, the shorter the time from slow to fast speed when motor starts
B2	Selection of gate travel speed to reset travel limits (after power failure etc.)	0-1	1	0 = Slow speed learning (press and release close button) 1 = Fast speed learning (press and hold close button till the end of the travel)
B3	Motor rotation direction setting	0-1	0	0 = Forward direction 1 = Reverse direction
C3	Delay time before closing automatically	0-99	0	0 = Will cancel auto closing function 3 = The door will auto closing after 3s
C5	Pedestrian opening distance setting	0-99%	50%	
C6	Soft stop selection	0-2	0	0 = Soft stop 1 = Slow down and then stop 2 = Scram
D0	PCB Model Number			Display PCB Model & Software version Number
D1	PCB Software version			
D2	Restore factory default setting	0-9		" 09 " = restore factory settings
D6	Charging voltage	0-48		The voltage should be higher than 27V
D7	Charging current	0-16		Display more than 5 , means it's charging the battery now
D8	Battery capacity display	0-99		Below 30 = battery will be run out soon 99 = Fully charged Please ignore this value when batteries are not connected
D9	Battery Voltage Display	0-28		Please ignore this value when the batteries are not connected





Solar System Installation



Solar Panel Installation

1. Measure and mark halfway along the long sides of both solar panel sides.
2. Place the holding brackets over this halfway point and mark the holes.
Attach the plastic washers to the holding brackets and holding arms
3. Carefully drill the 4 holes with a 13/64 drill bit and be sure you don't drill into the glass. Use a piece of thin metal between the frame you are drilling and the white to protect it.
4. Place the holding brackets and use the 10mm screws and bolts to hold in place
(You can also use the 4*13mm hex screws included).
5. Install the holding arm to the holding brackets with the 25mm screws and bolts.
This can be done after you attach the holding arm to your fence post with the wiring. For maximum sun exposure, align the solar panel so the bottom is facing sunrise and the top is facing sunset.

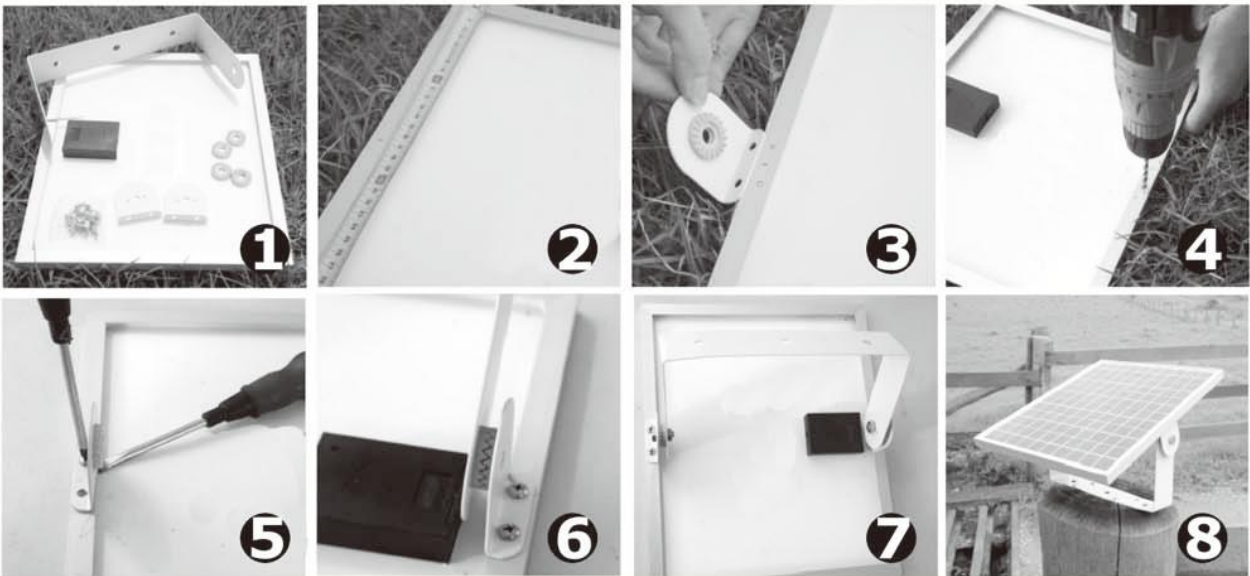

* If you choose solar power system, suggest to use Ahouse solar panel (2pcs 20W solar panel) to make sure the motor work properly.

* Our standards components doesn't include the cable connecting the control board to the solar panel

Solar Panel Wiring Instruction

1. Using the cables, connect one cable to the positive (+) terminal of the solar panel. Connect the other end of the same cable to the positive (+) terminal of the solar panel terminal in the control board (terminal 11 - see page 5).
2. Using the other cables, connect one cable to the negative (-) terminal of the solar panel. Connect the other end of the same cable to the negative (-) terminal of the solar panel terminal in the control board (terminal 11 - see page 5).



Battery Wiring Instruction

1. Using the supplied wire, connect the connector to the positive (+) terminal of one of the batteries. Connect the other end of the wire to the negative (-) terminal of the OTHER BATTERY.
2. Using the other wire, connect the connector to the positive (+) terminal of the battery. After the batteries are installed, the other end will be connected to the control board.
3. Using another wire, connect it to the negative (-) terminal of the battery. After the batteries are installed, the other end will be connected to the control board.

Note: make sure the bare ends of the wires do not touch together or do not touch the same metal surface at the same time.

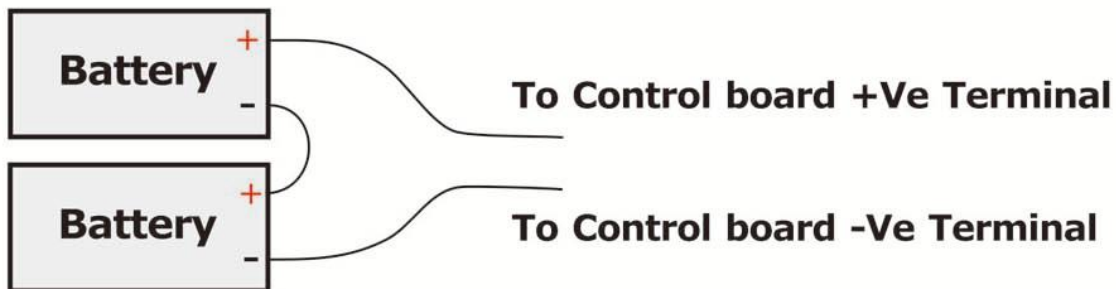

4. Install the batteries in the control box using cable ties as shown.

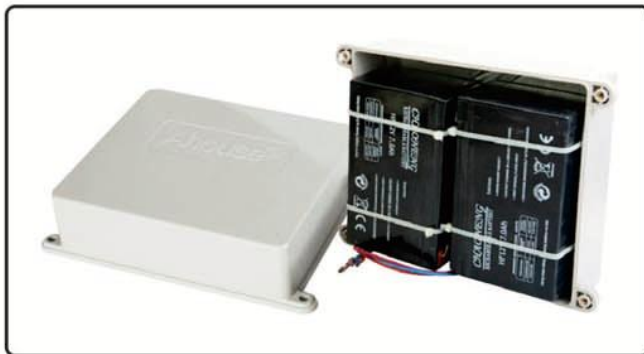

5. Connect the other end of the wire that is already connected to the positive terminal (+) of the battery to the positive (+) terminal in the control board for the battery (terminal 9 – see page 5).
6. Connect the other end of the wire that is already connected to the negative (-) terminal of the battery to the negative (-) terminal in the control board for the battery (terminal 9 – see page 5).

Battery Maintenance

Before use the batteries, please make sure that they are fully charged, it will lead to wrong operation if it is not fully charged, and need to check or replace the batteries by qualified person on a regular time basis.

- * Using 2 x 12V 9Ah batteries in series wiring for the solar panel backup power.
- * Battery is consumable, suggest to change battery every 9 or 12 months depending on usage and other factors.



PCB

Self Debug and Error Code List

Items	Descriptions	Remarks
L0	Voltage from AC mains supply or Battery is too high	
L1	Voltage from AC mains supply or Battery is too low	
L3	Voltage from +12V accessories terminal is too high	
L4	Voltage from +12V accessories terminal is too low: The current of accessories connected to +12V is too high	Please make sure the current of all the accessories connected to 12V are less than 300mA Check if the accessory is faulty or shorted
L5	Voltage from hall sensor terminal is too high	
L6	Voltage from hall sensor terminal is too low	
L7	Auto Reverse when meet obstacle more than 5 times	
L8	Motor wires are reversely	
L9	Door is opened abnormally	
n0	One of the hall sensors failure	
n1	Charge protection (battery terminal short circuit)	Please check the wiring of batteries
n3	The motor is not connected or motor wiring failure	
n4	Hall sensor doesn't count the number of running cycles	
n6	Gate can't be opened or closed : To check there is an Emergency stop signal or photocell detect something or there is an open signal	
n7	Gate can't be opened or closed : To check if the limit sensor senses the magnet	
n8	Restart after power off	Please press "⏏" on the remote control or "close button" to let gate travel to closed position and stop
E1	Pressed the button connected to the "Stop" terminal	
E2	Using limit switch stop	
E3	Reach the end of the travel without limit switch	
E5	Hampered stop or Hall sensors failure	
E6	Pedestrian opening and closing stop	
E8	Press "stop" button on the remote control	
E9	Motor stop working relate to any optional accessories connection to terminal "Open/Stop/Close"	



SD

Solar Sliding Gate Opener with self Debug Function



Suitable for
residential yard gate

DC 24V Opener, the design of fashionable outline.
Easy Self learning feature.
Commercial & solar energy power source can be connected at the same time.
Digital gate limit positioning system.
Pedestrian open and full open adjustable, opening range can be adjusted.
Auto close function with adjustable closing time delay.
Backup battery is available, can work during power failure, battery status display.
Self Debug function built-in.

