

Installation Guide

Version 01-20C

EM Swing Gate Opener

Features	1
Technical Specifications	
Mechanical Installation	2
Manual Release	5
Control Box Wiring	6
Wiring for Optional Accessories	7
Remote Control Setting	8
Self-learning	9
Solar System Installation.....	13
Self Debug and Error Code List	16
Gate Lock Installation	17
Flashing Light Installation	18



Standard
 Solar

1. Features

1. Manufacturer has patent for manual release mechanism. Use this feature in case of power failure, during installation or maintenance
2. Unique easy self-learning feature (Page 9)
3. Commercial power & solar energy power source can be connected at the same time
4. Over current immediate stop function (A0~A1/ B0~B1)
5. Adjustable time of fast speed & slow speed (A2~A5/ B2~B5)
6. Adjustment of force during fast speed & slow speed (A6~A7/ B6~B7)
7. Auto Close function with adjustable closing time delay
8. Use max up to 99 sets of remote controllers
9. Optional Devices: Backup battery, DC24V gate lock, photocell, keypad system, flashing light (AC110V/220V) & DC24V, push button, etc.
10. Low power consumption, static current low to 15mA/30V, upgraded for rainy and cloudy seasons.
11. New design to improve power charging efficiency.
Super high voltage protection design for solar panel terminal.
12. PCB Built-in smart self -detect and self-protection
13. New added error code self checking LED message
14. Built-in Modbus-RTU protocol
15. New advanced built-in 32 bits /48MHZ CPU

2. Technical Specifications



EM

■ Electrical

Operating Voltage	DC 24V
Electronic Controller	Microcontroller Based
Safety Detection	Over Current Detection
Safety Barrier	Infrared Beam Sensor (Optional)
IP Rating	IP66

■ Mechanical

Swing Type	EM3 Plus	EM 3	EM 2
Max. Piston Stroke	450 mm	350 mm	200 mm
Max. Length of motor	1255 mm	1030 mm	730 mm
Max. Leaf's Weight	250 kg/ Leaf	300 kg/ Leaf	300 kg/ Leaf
Suitable Leaf's Length	2 to 3.5 meter/ Leaf	1.5 to 2.5 meter/ Leaf	1 to 1.6 meter/ Leaf
Frame Housing	304 Stainless Steel / Aluminum Alloy		
Driving Method	Screw Driven Piston Type		
Opening Degree	0 to 110 degree		
90 Degree Rotation Time	8 to 12 seconds		
Temperature	-15°C to +55°C		

EM

Swing Gate Opener

3. Mechanical Installation

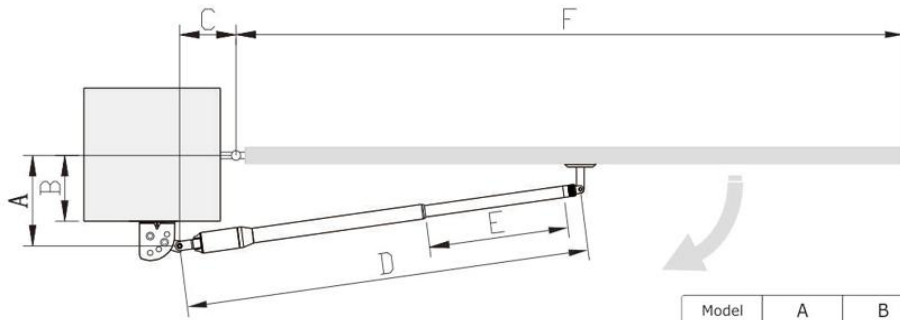

**Inward
Swing**

Measurement: mm

Model	A	B	C	D	E	F
EM3 Plus	≤275	≤200	≤180	1320	450	≤4000
EM3	≤225	≤150	≤130	1086	350	≤2500
EM2	≤80	≤40	≤80	786	200	≤1500

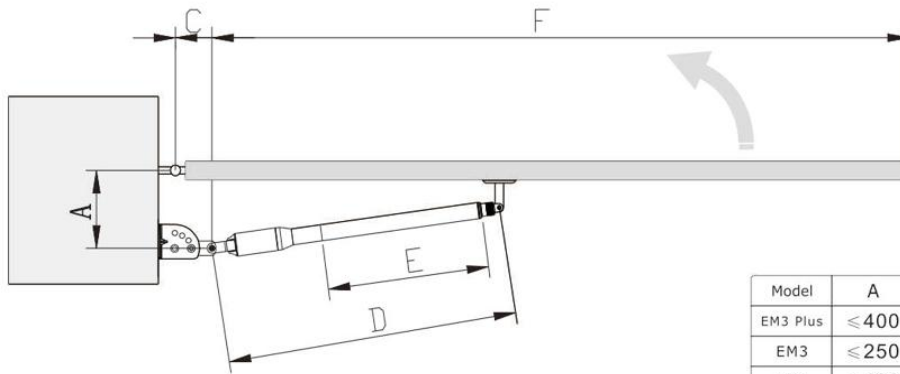

**Outward
Swing**

Measurement: mm

Model	A	C	D	E	F
EM3 Plus	≤400	≤180	870	450	≤4000
EM3	≤250	≤100	736	350	≤2500
EM2	≤120	≤80	586	200	≤1500

Diagram Installation

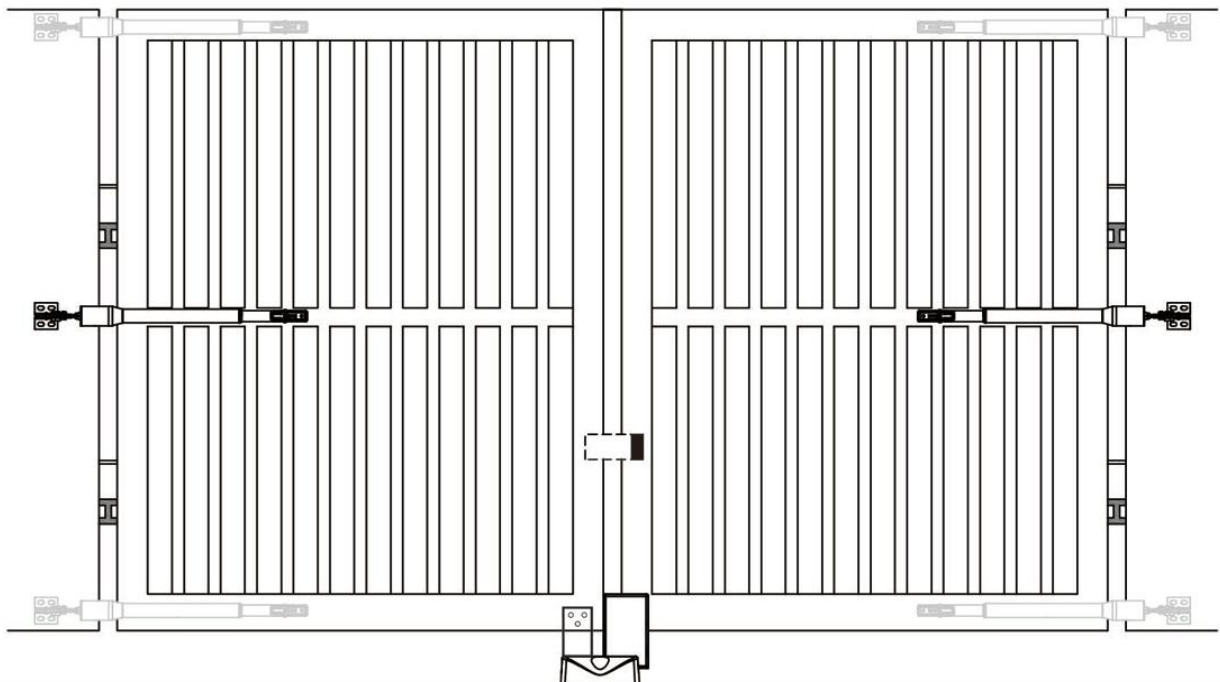

EM

Swing Gate Opener

Opener Dimension

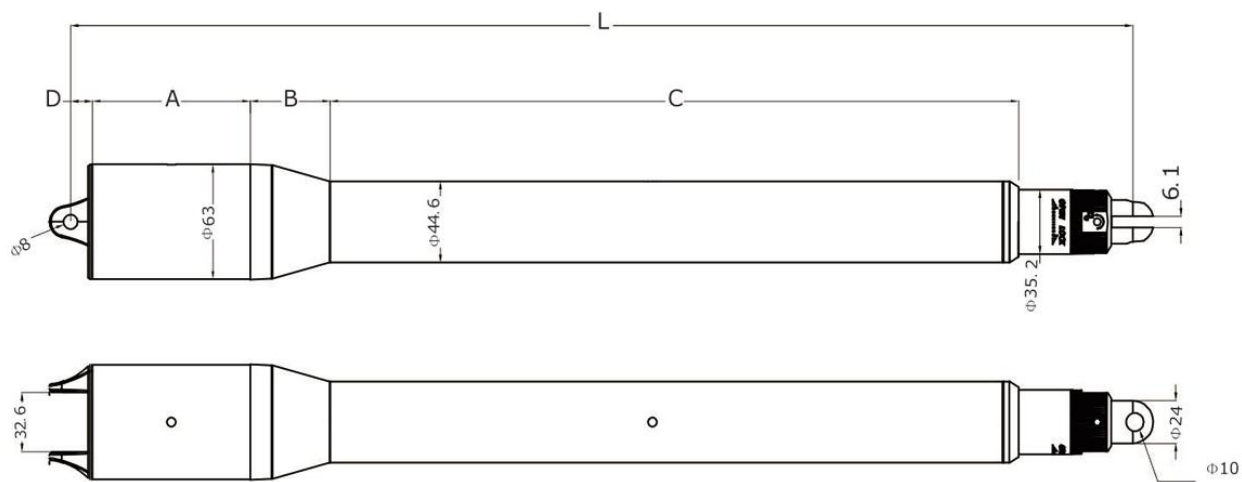

Measurement: mm

Piston Stroke	A	B	C	D	L
200	135	45	275	12.5	530/730
350	135	45	425	12.5	680/1030
450	135	45	550	12.5	805/1255

Bracket Dimension

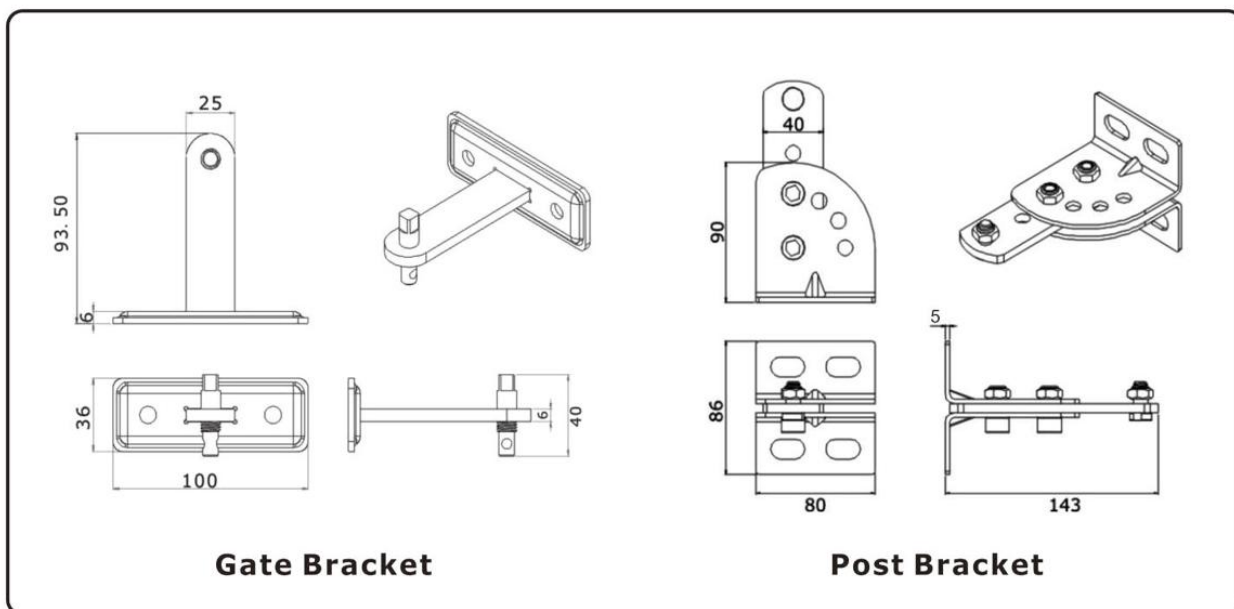

Measurement: mm

EM

Swing Gate Opener

Installation Precautions

1. Please make sure there is some angle between the position of the gate bracket and the post bracket.
These two brackets should not be parallel to each other.

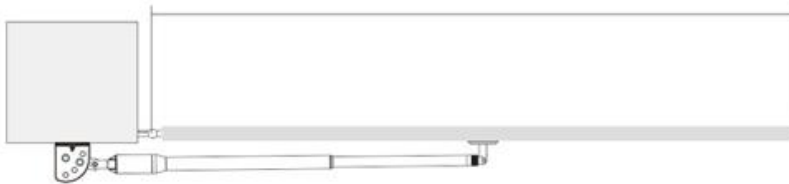
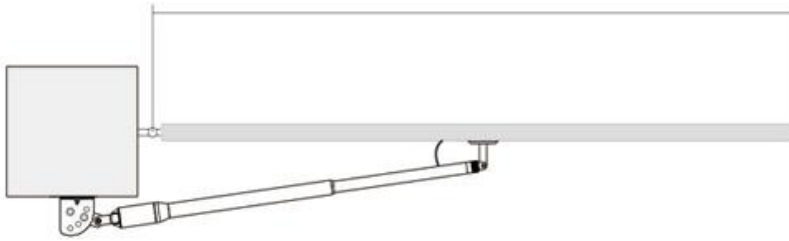

2. Ensure the motor has at least 5mm of travel left in the open position (inward swing) or closed position (outward swing).
3. There are two small holes on the swing arm motor , please make sure these holes are facing down to ensure weatherproofing.
4. The motor must be completely level once installed. To check, use a level on the motor. DO NOT install the motor on an upward and downwards slope towards the gate.

4. Manual Release

In case of power failure , the motor can be disengaged from the gate . Follow the directions below to release and rotate the motor to enable the manual release function.

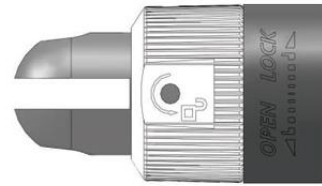

1. Use the special key to unlock the manual release function.
2. Turn the neck of the arm 90 degree or 1/4 turn towards the open position.
3. The manual release is now activated and the motor disengaged.
You can now move the gate by hand freely .
4. To re-engage, turn the neck of the arm back towards the lock position while gently rocking the gate back and forth.
Use the special key to lock off the manual release function.

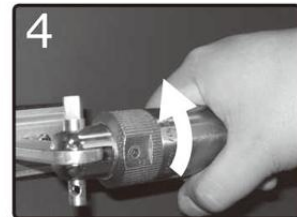
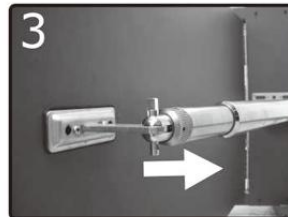
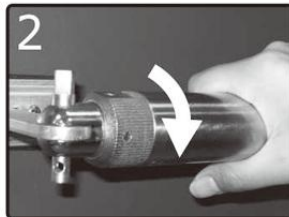

Control Box Wiring

1. Wiring

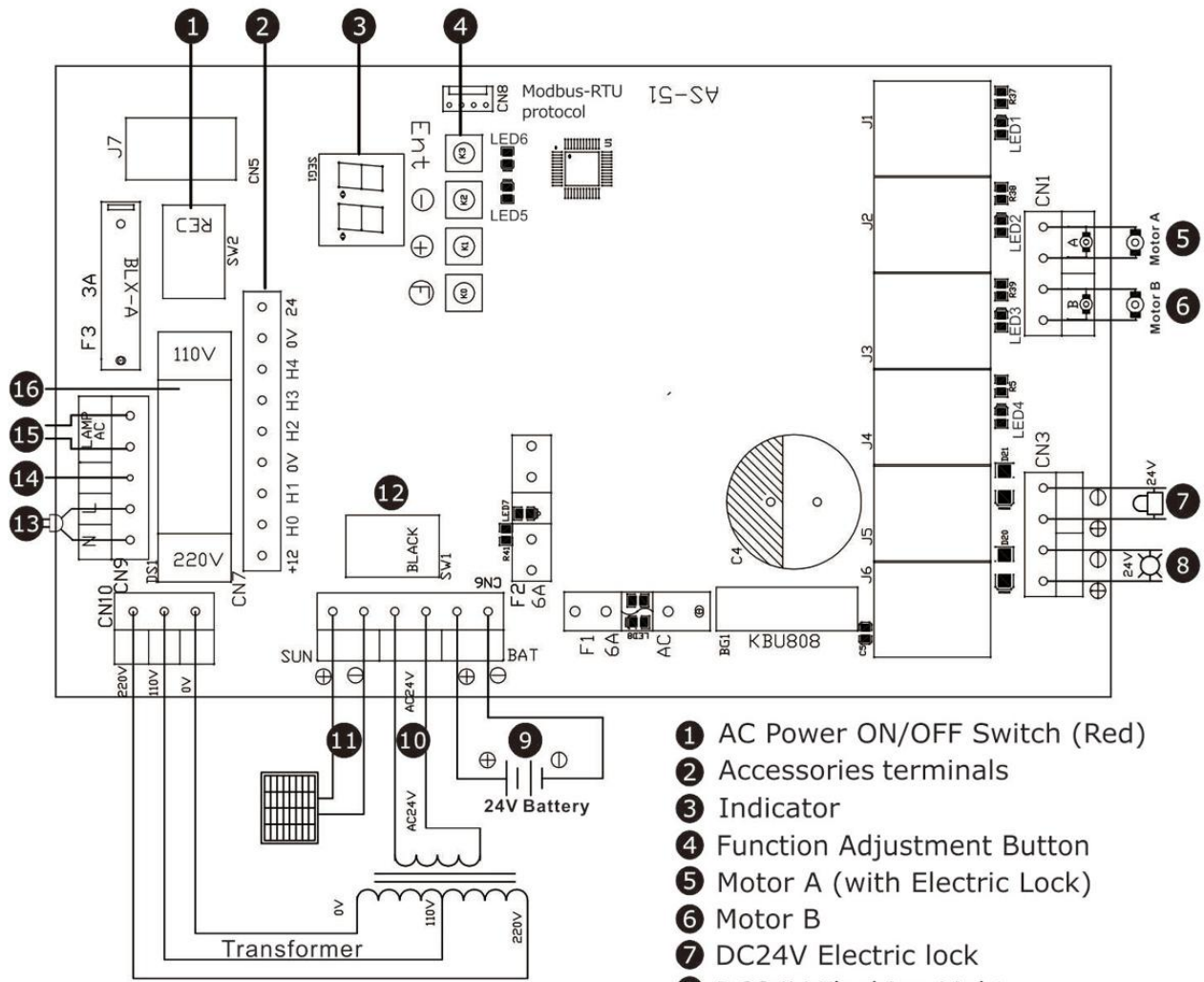

- 1 AC Power ON/OFF Switch (Red)
- 2 Accessories terminals
- 3 Indicator
- 4 Function Adjustment Button
- 5 Motor A (with Electric Lock)
- 6 Motor B
- 7 DC24V Electric lock
- 8 DC24V Flashing Light
- 9 Backup Battery (12V 9ah x 2 in series)
- 10 AC24V terminal for transformer
Only accept AC24V to 26V voltage
- 11 Solar Panel
- 12 Power ON/OFF Switch (Black)
(AC power and battery)
- 13 Power Supply (AC220V / 110V)
- 14 Earth wire connection
- 15 AC Flashing Light
(not used in 24V system)
- 16 Selector Switch for AC220V or 110V

LED Diagram

Power On, LED5 will blink.

- LED1 Motor A open LED
- LED2 Motor A close LED
- LED3 Motor B open LED
- LED4 Motor B close LED
- LED5 Power LED
- LED6 Received signal for remote control LED

- * Make sure the "16 selector switch for AC 220v or 110V" is at the correct position before power on
- * Please switch off the power before connecting any accessories
- * The solar system doesn't include transformer, if you need to use AC220V or 110V mains power, please add a transformer first



EM

Swing Gate Opener

2. Wiring for Optional Accessories

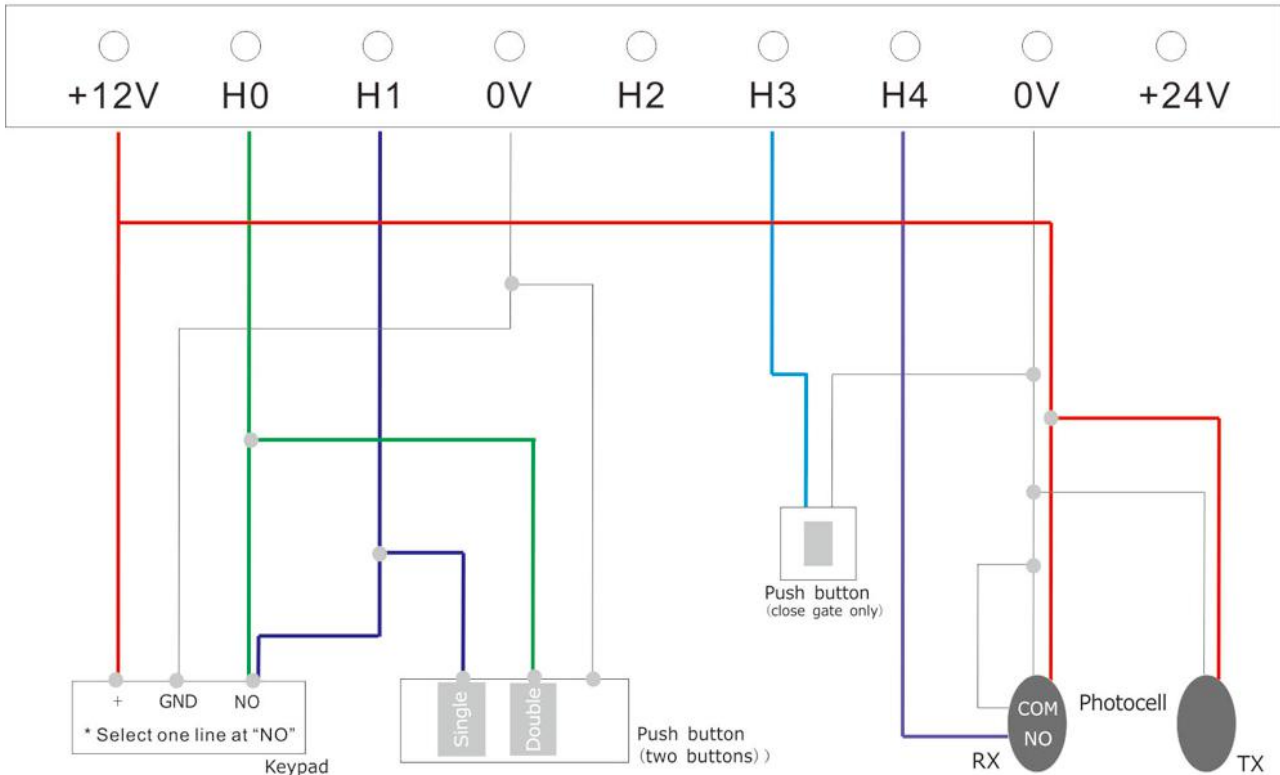

Item	+12V	H0	H1	0V	H2	H3	H4	0V	+24V	Remarks
Description	Stable voltage output	Dual Open/Stop/Close	Single Open/Stop/Close	"-" & "Concentration line"	Only OPEN	Close	Sensor	"-" & "Concentration line"		
Keypad (single open)	•		•	•						
Keypad (dual open)	•	•		•						
Push button (two buttons)		•	•	•						
Push button (one button)			•	•		•		•		close gate only
				•						single open
		•		•						dual open
Photocell (sender)	•							•		
Photocell (receiver)	•						•	•		

"•" Means the connection port

*Please switch off the power before connecting any accessories

Instructions for photocell

During gates closing, if the photocell detect any obstacles, the gates will stop immediately and then reverse back. Only until the obstacles be removed, the gates will operate according to new command.

EM

Swing Gate Opener

How to Connect the Motors

Motor A:

Connect the two wires from the motor to the "Motor A" terminals marked letter "A" (see page 6, Shown as terminal 5.)

If you find the motor is operating in the wrong direction, reverse the motor wires on the circuit board.

Motor B:

Connect to terminal marked letter "B" (see page 6, Shown as terminal 6.)

3. Remote Control Setting

Activating the Remote Control

Press and hold the "F" button for approximately 2 seconds until the indicator displays "FF" and keeps flashing , then release the "F" button.

Press "□stop" button on the remote control, if the display stops flashing "FF", it means the remote control is programmed to the PCB and is valid.

- * 99 remote controls can be set at most
- * Verify the remote control is operating by pressing a button on the remote, when any button is pressed on the remote control, LED6 (on the PCB) will be on.

Erasing the Code

Press and hold the "F" button for approximately 2 seconds until the indicator displays "FF" and keeps flashing , then release the "F" button.

Press and hold the "Enter" button until the display stops flashing "FF", this indicates all remotes have been erased and are invalid.

**Pedestrian opening push "P" button to perform single swing opening

(Note: Only valid for double swing systems)

- * When remote control signal weakens , please replace the battery of remote control and check the receiver on the control board
Weak signal will shorten the distance of remote control or send wrong instruction to control board
- * If the remote control can't be set , please Erasing all the code and then activate the remote control you want to use



Function adjustment button

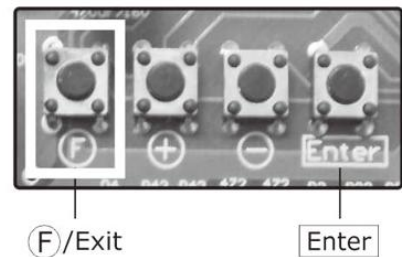

433MHZ Remote control



The remote control cyclic form is " open - stop - close "

EM

Swing Gate Opener

4. Self-learning (Easy and Smart)

Checking before self-learning

1. Check the wiring of the motors
2. Check the manual release is in the locked position
3. Make sure the gate(s) are in the **fully open** position.
4. There should be hard stoppers at both fully opened positions and fully closed position.
5. Please disconnect the solar panel when doing the self-learning, connect the solar panel after done the self-learning

Self-learning setting (motor setting)

1. Press the "F" button on the PCB. If d7 is not on the display, Tap the "+" or "-" button until it is shown.
 2. Hold down the "Enter" button on the PCB for 3 seconds until the display starts to blink and release the button. This enters self learning mode.
 3. Self-learning is finished when d7 is steady on the display. You can now use the remote control.
- * Do not operate the remote control during the above self-learning process. Press the "F" button to exit the learning mode if you require an emergency stop. to restart the self learning process, start from step 1.

If you find problems with the gate operation in heavy winds or with other obstacles, adjust "MOTOR SETTING" and total timer adjustment manually as stated on page 10.

STEP 1

Gate Fully Opened



indicator

PCB Function adjustment button



F/Exit + - Enter

STEP 2

System Self Learning

EM

Swing Gate Opener

PCB Manual Adjustment

After the self-learning process if manual adjustment is required to get optimum parameters, please following below:

If opening or closing does not reach the required positions, you can increase the force during slow speed (A6,B6) by 10 and then repeat the self-learning process.

If the speed is not slowing down at the ends of the cycle, decrease A6 and B6 by about 5 and then repeat the self-learning process.

Note:

1. After the above adjustment and the opening or closing is still not reaching the designated position, is slower than normal, or does not function, the following reason may be caused by:
 - a. The motor will not work if the supply voltage is outside operating parameters. Please confirm the input voltage is within $\pm 10\%$ of 24 volts
 - b. Advise to choose above 2.5 square mm with copper wire. It will be better to increase the wire diameter if long distance wiring.
 - c. Adjust the motor installed position.
2. In case if you have changed the parameters, make sure to restore factory default settings before proceed with self-learning procedure. (Set d2)

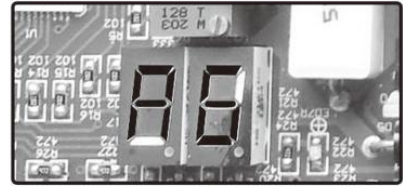

STEP **3**

Manual Adjustment

EM

Swing Gate Opener

Function Adjustment

(Follow the steps below)

Step 1: Press "F" button, the indicator will show "d7"

Step 2: Press "+" button, it'll show in turn "d8,d9,dA,H0,H1,H2,H3,H4"
Press "-" button, it'll show reversely

Step 3: Press "F" button, after choose the item, the indicator will show numbers

Step 4: Press "+" or "-" button to select levels

Step 5: Press "Enter" button to confirm

Step 6: Press "F" button for return to previous configuration menu

Function Debug Form

Code	Function / Explanation	Setting Range	Default Setting	Remarks
A0/b0	Intermediate Stop Function with slow speed. This refers to the sensitivity of gates when meeting obstacles during slow speed operation.	0~99	17	Lower setting means the gates will be more sensitive to stopping.
A1/b1	Intermediate Stop Function with high speed. This refers to the sensitivity of gates when meeting obstacles during high speed operation.	0~99	45	Higher setting means the gates are not as sensitive to stopping on hitting an obstacle.
A2/b2	Time of opening - slow speed. Low speed operating time during gate opening.	0~9.9s	9s	This is the time it takes to Open/Close the gate for the Slow Speed part of the sequence.
A4/b4	Time of closing - slow speed. Low speed operating time during gate closing.	0~9.9s	9s	
A3/b3	Time of opening - high speed. High speed operating time during gate opening.	0~99s	10s	This is the time it takes to Open/Close the gate for the Fast Speed part of the sequence.
A5/b5	Time of closing - high speed. High speed operating time during gate closing.	0~99s	10s	
A6/b6	Force of opening and closing - slow speed. Force adjustment for low speed operating during open and close.	0~99	56	This is the force the motor applies on the gates. If the gates are heavy, you will need more force to speed up the opening and closing of the gates. (Note: if the gates can open/close into position, you do not need to adjust the default settings.)
A7/b7	Force of opening and closing - high speed. Force adjustment for high speed operating during open and close.	0~99	99	
C0	Reverse swing of motor A.	0~2	2	No need to adjust this if the gate installed has end stoppers.
	If you choose "0", the gate system will not have gate lock function or reverse swing operation.			
	If you choose "1", the gate system will have gate lock function but no reverse swing operation.			
C1	Electric lock.	0~1	1	When activated (Option "1"), the gates can't be pushed open.
	If you choose "0", the gate system will not have gate lock operation after gate is closed.			
	If you choose "1", the gate system will have gate lock operation after gate is closed.			
C2	Motor delay setting.	0~3	2	
	If you choose "0", only motor A working, motor B do not working			
	If you choose "1", motor B will delay open during opening.			
	If you choose "2", motor B will delay open during opening, motor A will delay start during closing.			
	If you choose "3", motor B and motor A will start working at the same time.			

EM

Swing Gate Opener

Code	Function / Explanation	Setting Range	Default Setting	Remarks
C3	Time of auto close.	0~99s	0	
	If you choose "0", the gate system will not have auto closing function.			
	If you choose "10", it means the gates will automatically close 10 seconds after completing its opening.			
C4	Time delay for opening, and delay for closing. During opening, motor B will open a little later than motor A During closing, motor A will close a little later than motor B	0.1~9.9s	2	
C5	Delay activating time for remote control button (for avoiding misoperation)	0~1	0	
	If you choose " 0 ", normal operation			
	If you choose " 1 ", press and hold the button 2 seconds then start the operation			
C6	Operating time of lock when opening the gate	0.9~5.0	1.7	
C7	Reverse swing of motor B when start opening	0~1	0	
	If you choose "0", the motor B will not have reverse swing operation.			
	If you choose "1", motor A and B will have reverse swing operation.			
C9	Reserved terminal for maintenance and testing			
d0	PCB Model Number			Display PCB Model & Software version Number
d1	PCB Software version			
d2	Restore default setting " 09 " = restore factory settings		0	
d3	" Only Open " terminal function *Cancel under voltage warning	0~1	0	0 = when receive a signal from this terminal, gate won't move after fully open 1 = The signal can continue opening gate after fully open *97 = Cancel the function: motor stops working and show L1 on the displayer when power supply voltage is too low
d4	Motor A Current display during operating	0.1~9.9 A		
d5	Motor B Current display during operating	0.1~9.9 A		
d6	Charging Voltage	24~48V		The voltage should be higher than 27V
d7	Charging Current	00~16A		
d8	Battery Capacity Display	00~99		Below 20 = Battery soon will be run out 99 = Fully charged
d9	Battery Voltage Display	00~28V		
d7	Self-learning feature			Press & hold "Enter" button to turn to self-learning mode

✳ Use this guide to help trouble shoot gates that are not operating properly. You can also set the delay functions by this guide.

1. For most of these functions, it's only necessary to adjust them if the system is not opening or closing as desired.
2. Default settings can be reset directly from the Control Box.
3. Please note that the gates open and close in the following manner: soft start, fast swing and slow finish. To adjust each of these speeds, refer to the chart above.



Solar System Installation

Solar Panel Installation

1. Measure and mark halfway along the long sides of both solar panel sides.
2. Place the holding brackets over this halfway point and mark the holes.
Attach the plastic washers to the holding brackets and holding arms
3. Carefully drill the 4 holes with a 13/64 drill bit and be sure you don't drill into the glass. Use a piece of thin metal between the frame you are drilling and the white to protect it.
4. Place the holding brackets and use the 10mm screws and bolts to hold in place
(You can also use the 4*13mm hex screws included).
5. Install the holding arm to the holding brackets with the 25mm screws and bolts.
This can be done after you attach the holding arm to your fence post with the wiring.
For maximum sun exposure, align the solar panel so the bottom is facing sunrise and the top is facing sunset.

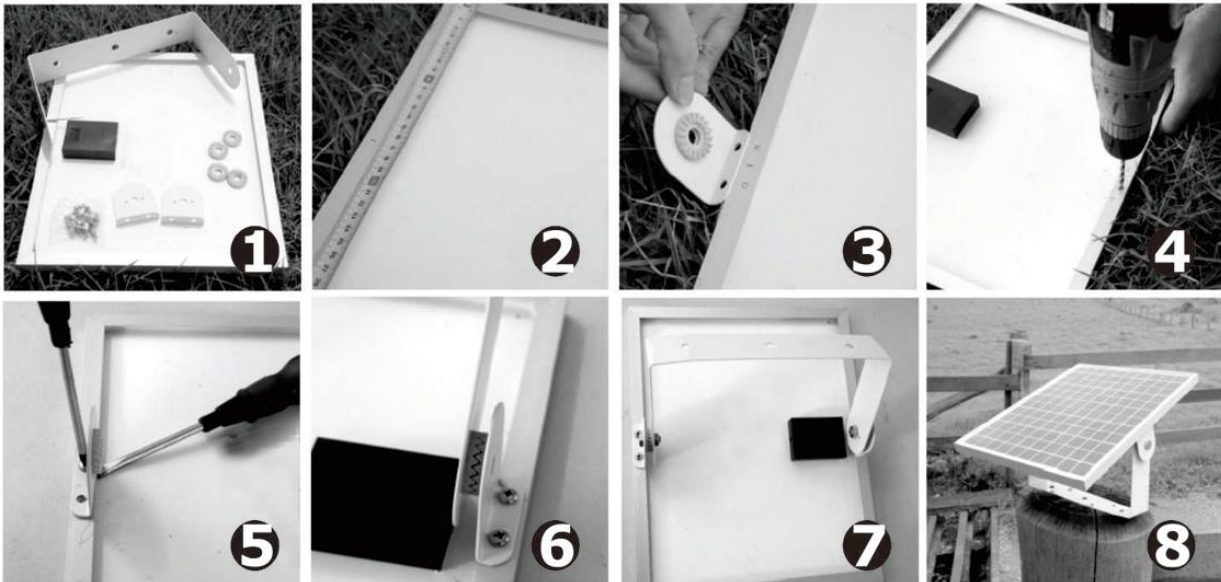

* If you choose solar power system, suggest to use Ahouse solar panel(20W solar panel) to make sure the motor work properly.

Solar Panel Wiring Instruction

1. Using the cables, connect one cable to the positive (+) terminal of the solar panel. Connect the other end of the same cable to the positive (+) terminal of the solar panel terminal in the control board (terminal 11 – see page 6).
2. Using the other cables, connect one cable to the negative (-) terminal of the solar panel. Connect the other end of the same cable to the negative (-) terminal of the solar panel terminal in the control board (terminal 11– see page 6).

* Our standard components doesn't include the cable connecting the control box to the solar panel

Battery Wiring Instruction

1. Using the supplied wire, connect the connector to the positive (+) terminal of one of the batteries. Connect the other end of the wire to the negative (-) terminal of the OTHER BATTERY.
2. Using the other wire, connect the connector to the positive (+) terminal of the battery. After the batteries are installed, the other end will be connected to the control board.
3. Using another wire, connect it to the negative (-) terminal of the battery. After the batteries are installed, the other end will be connected to the control board.

Note: make sure the bare ends of the wires do not touch together or do not touch the same metal surface at the same time.

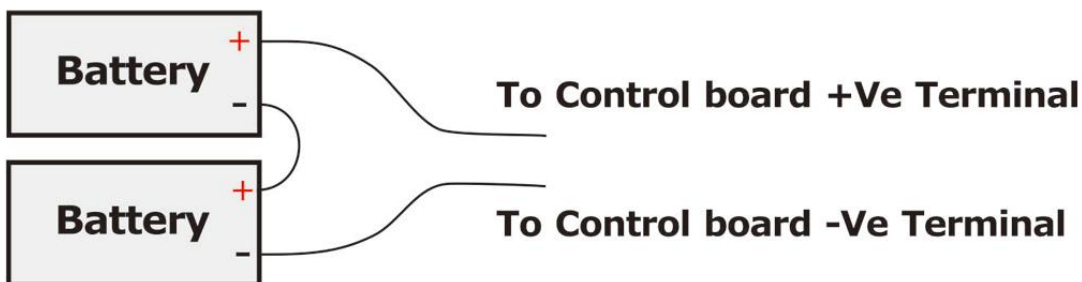

4. Install the batteries in the control box using cable ties as shown.



5. Connect the other end of the wire that is already connected to the positive terminal (+) of the battery to the positive (+) terminal in the control board for the battery (terminal 9 - see page 6).
6. Connect the other end of the wire that is already connected to the negative (-) terminal of the battery to the negative (-) terminal in the control board for the battery (terminal 9 - see page 6).

Battery Maintenance

Before use the batteries, please make sure that they are fully charged, it will lead to wrong operation if it is not fully charged, and need to check or replace the batteries by qualified person on a regular time basis.

- * Using 2 x 12V 7/ 9Ah batteries in series wiring for the solar panel back up power .
- * Battery is consumable, suggest to change battery every 9 or 10 months.

PCB

Self Debug and Error Code List

Items	Descriptions	Remarks
L0	Voltage from AC mains supply or Battery is too high	
L1	Voltage from AC mains supply or Battery is too low	
L2	Current of motor A is too high when overloading	
L3	Voltage from +12V accessories terminal is too high	
L4	Voltage from +12V accessories terminal is too low: The current of accessories connected to +12V is too high	Please make sure the current of all the accessories connected to 12V are less than 300mA Check if the accessory is faulty or shorted
L8	Current of motor B is too high when overloading	
L9	Motor terminal short circuit	Please check the wiring of motors
n1	Charge protection (battery terminal short circuit)	Please check the wiring of batteries
n3	The motor is not connected or motor wiring failure	If it is a single gate, suggest setting C2 to 0 If the motor works properly , single swing or testing then can ignore n3
n5	When C5 = 1 , Press and hold remote control less than 2 seconds , the remote control will not be functioned	
n6	Gate can't be opened or closed : To check there is an Emergency stop signal or photocell detect something or there is an open signal	
A8/b8	Gate A stops working (A8) Gate B stops working (b8)	0= Motor hasn't started yet 1= Pressed the button connected to the "Stop" terminal 3= Finished the total opening time 5= Hampered stop during high speed 6= Pressed the "P" button on the remote control 8= Pressed the "stop" button on the remote control 9= Stopped working relate to any optional accessories connection to terminal "H0" 10= Stopped working by the Modbus-RTU Communications Directive 11= Stopped working relate to any optional accessories connection to terminal "H1" 13= Finished the total closing time 15= Hampered stop during slow speed
dA	The last signal to open the gate	1= Signal comes from the Modbus-RTU Communications Directive 2= Signal comes from the "Open" button on remote control 3= Signal comes from the "H2" (Only open) terminal 4= Signal comes from the "H0" (Dual open/stop/close) terminal 5= Signal comes from the "P" button on remote control 6= Signal comes from the "H1" (Single open/stop/close) terminal 7= Signal comes from the "Single open" terminal 8= Signal comes from "reverse when meet an obstacle" 9= Signal comes from the "delay for opening"

Gate lock installation

Model: DS218

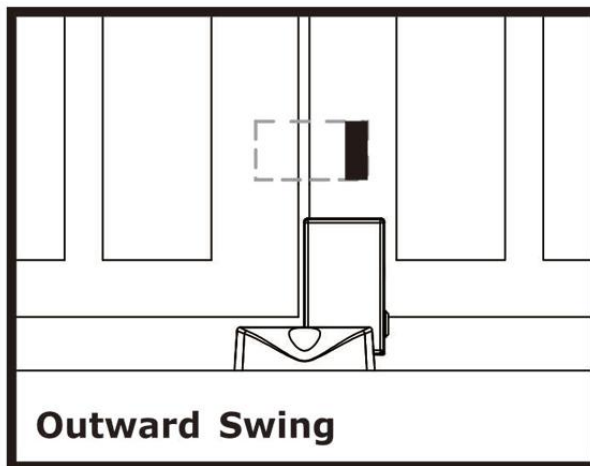
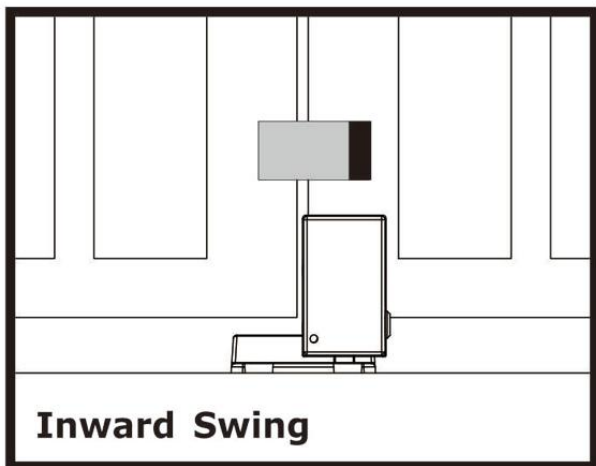

Installation

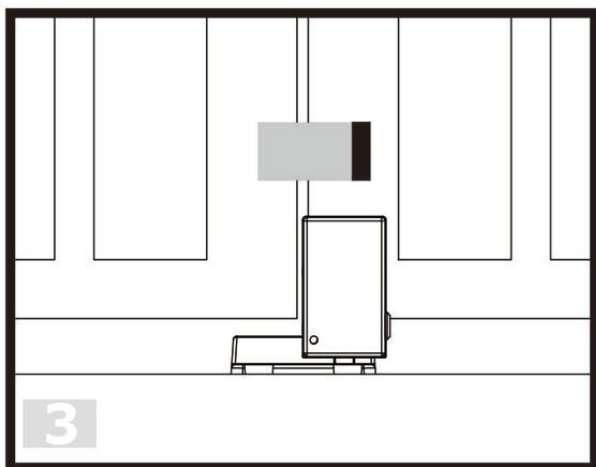
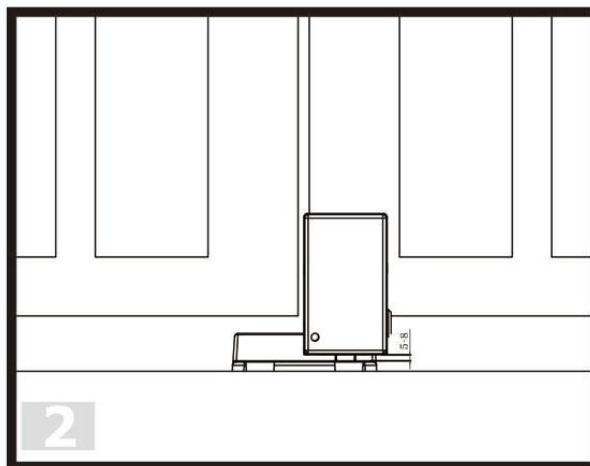
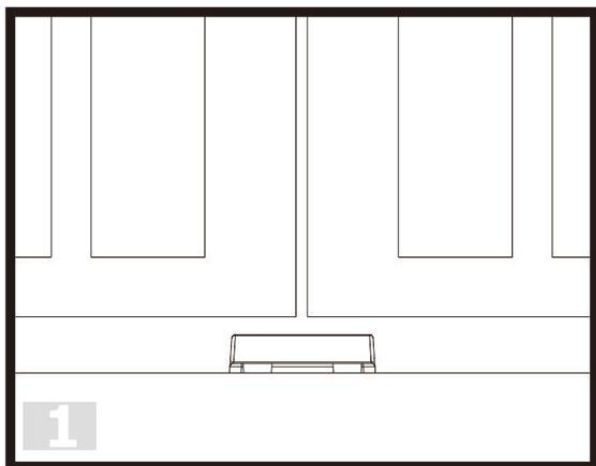

1. Install the stopper
2. Fix the lock body onto the first moving side of the gate leaf, make sure there is at least 5 to 8 mm space between the stopper location hole surface & the bottom of lock body.
3. Install the stopper plate in corresponding position onto the same leaf which installed with lock DS218, this is to make sure when 2 leaves are closed, the stopper plate can limit the leaf which cannot be opened either.

* The lock bolt pin must be in vertical position with the bolt pin of the stopper .

EM

Swing Gate Opener

Flashing light installation

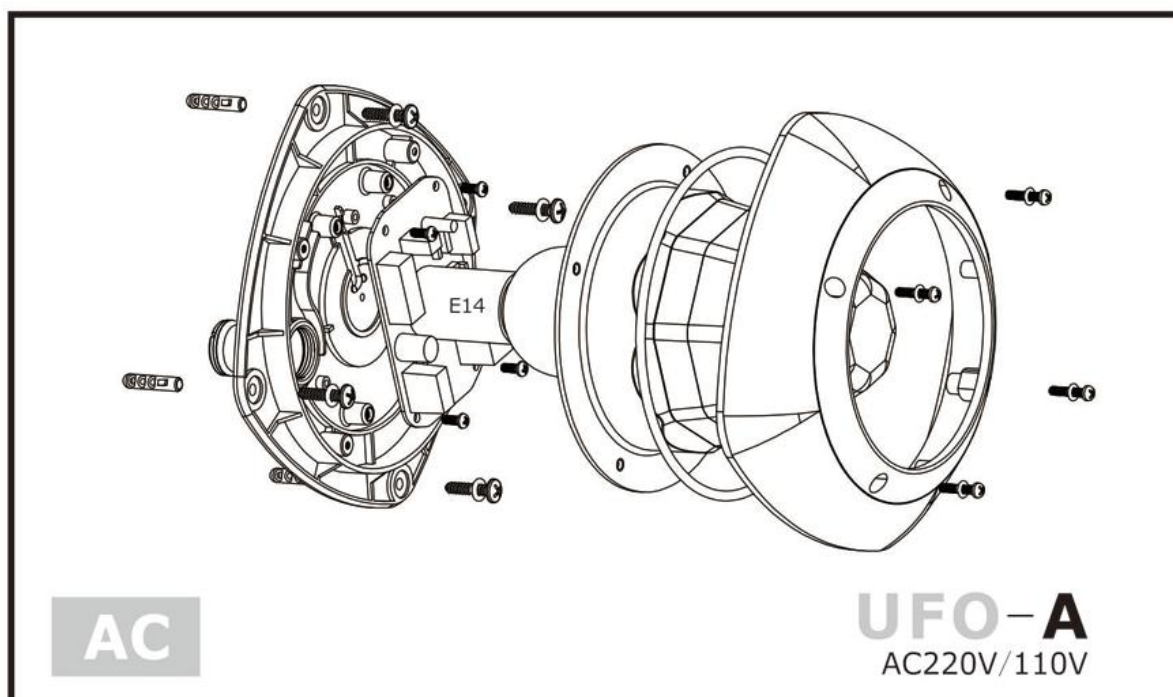
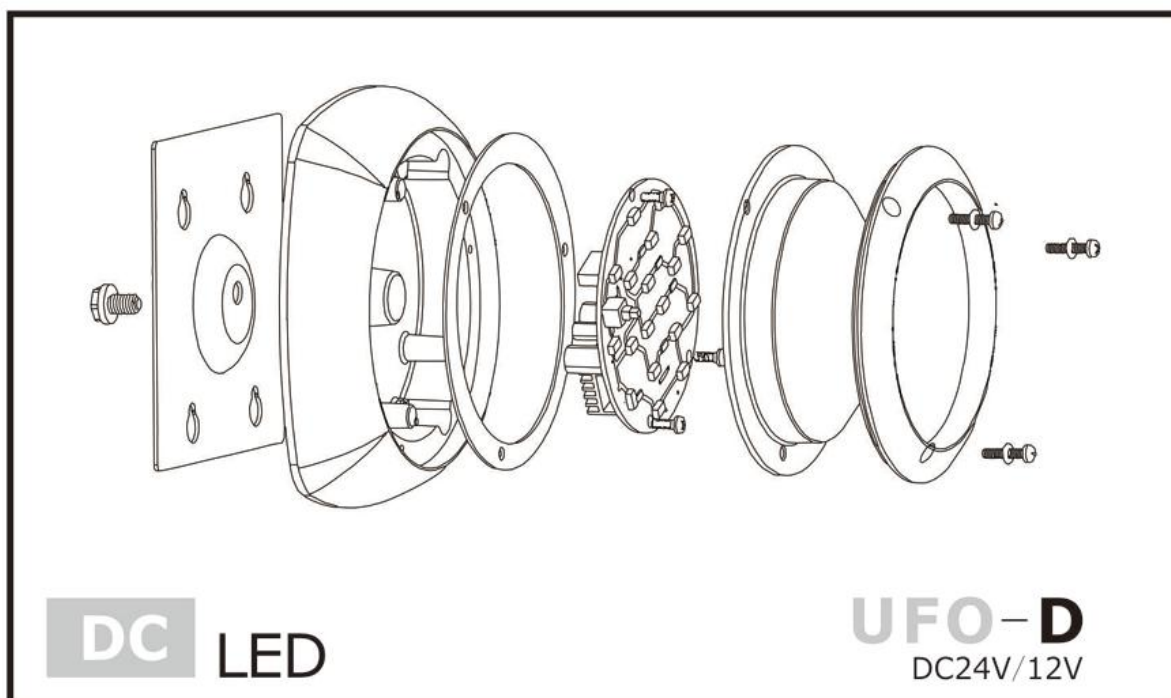

If using solar systems, connect with DC 24V flashing light only.

* wiring for flashing light, (see page 6)

EM

Swing Gate Opener



Swing Gate Opener

EM

Before Installation:

1. The gates must be in horizontal lines, make sure the gates and the gate post are in vertical positions.
2. Make sure the gates can be moved by hand push force, and can be easily stopped anytime.
3. The gates can be operated quietly and stably.
4. Make sure the gates can operated smoothly within the installation area.
5. The opening degree and the push force of the gate operator is related to the installation position of the gate brackets and the post brackets. So please read the manual carefully to make sure the installation is fit into the need of the consumers.
6. Before you fix the gate brackets and the post brackets, please first make sure the gate operator can be in fully horizontal position during both opening and closing gates, and it is no problem to open/close the gates manually.



DC 24V two wires Easy Installation
Unique manual release feature
Self Learning Function
Solar System Compatible